

Using key QC022-AK (0008.9022)  
Torque: 10 Nm

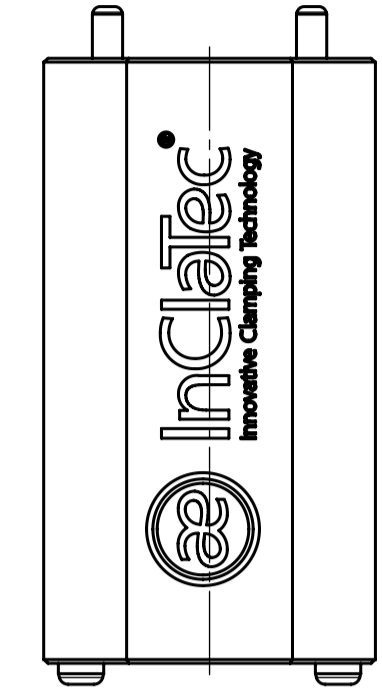

QuickChange Module  
QC022 / QC022 C

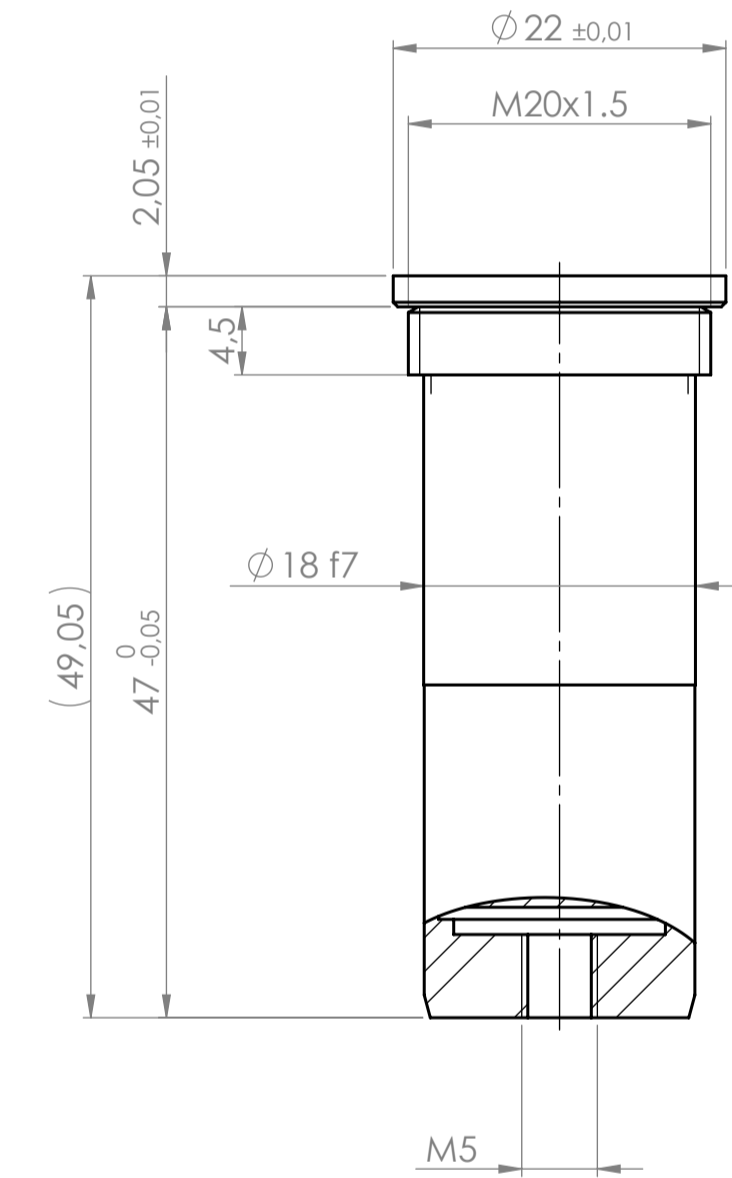

Option 1

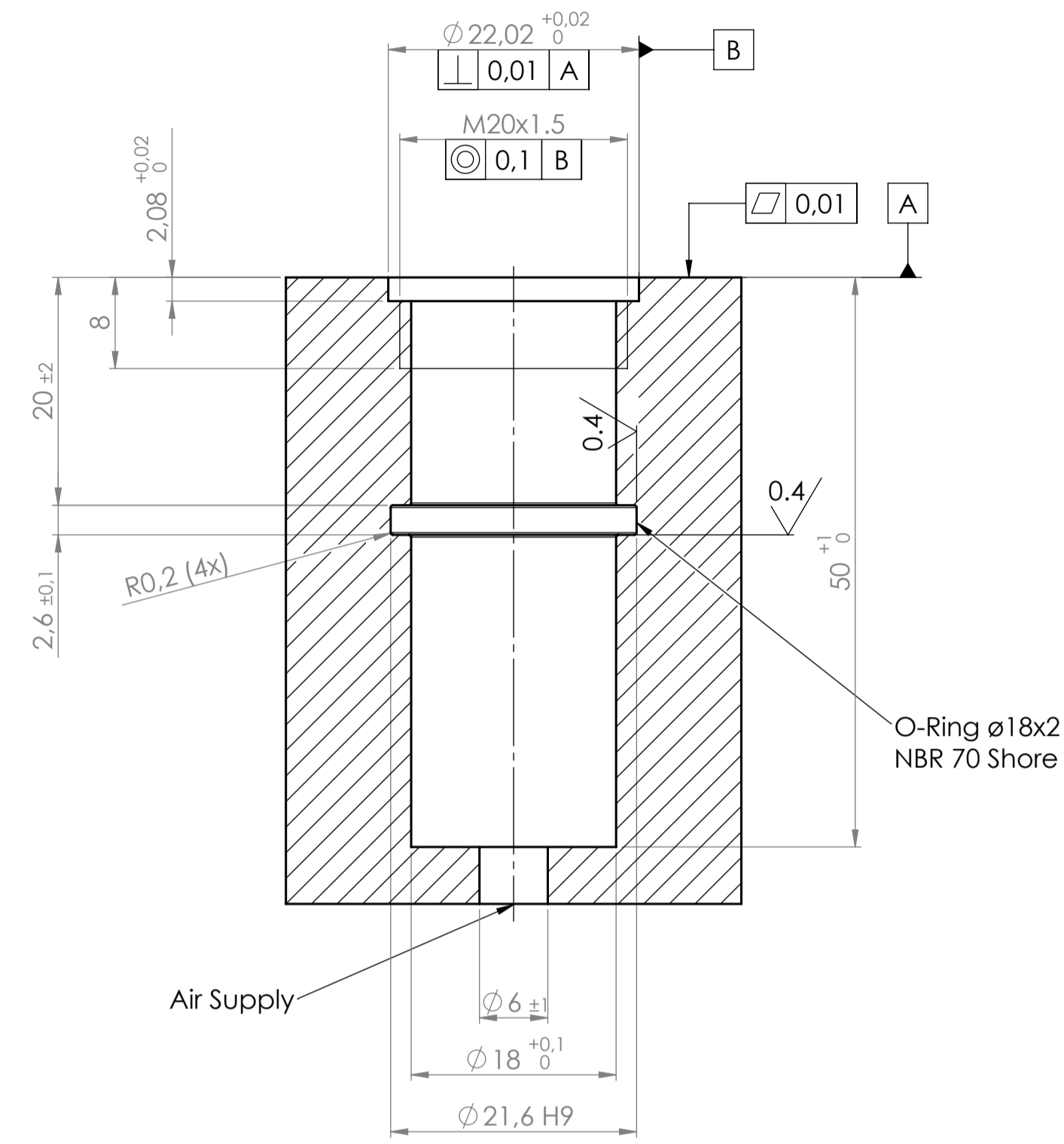

Option 2

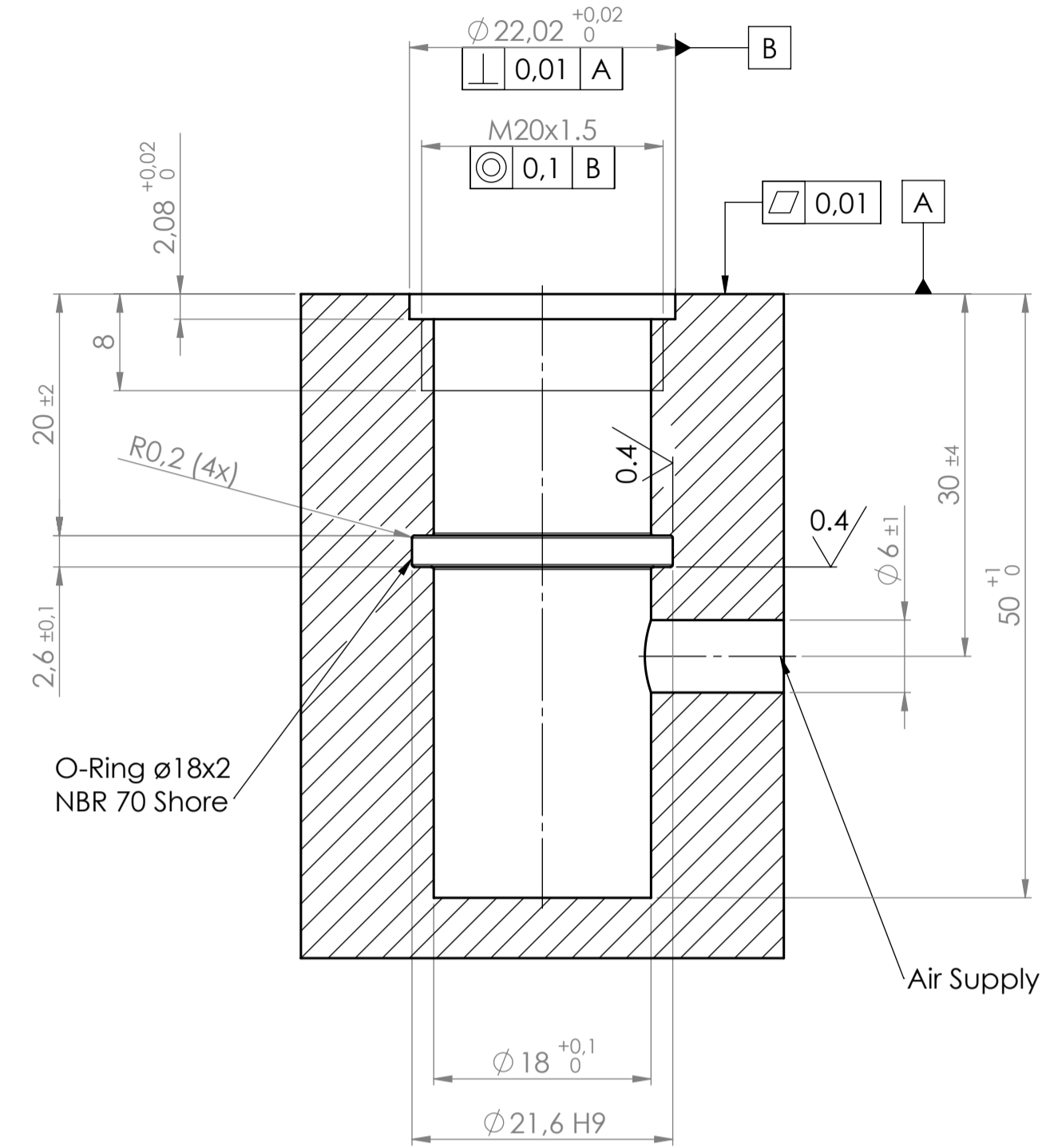

Option 3

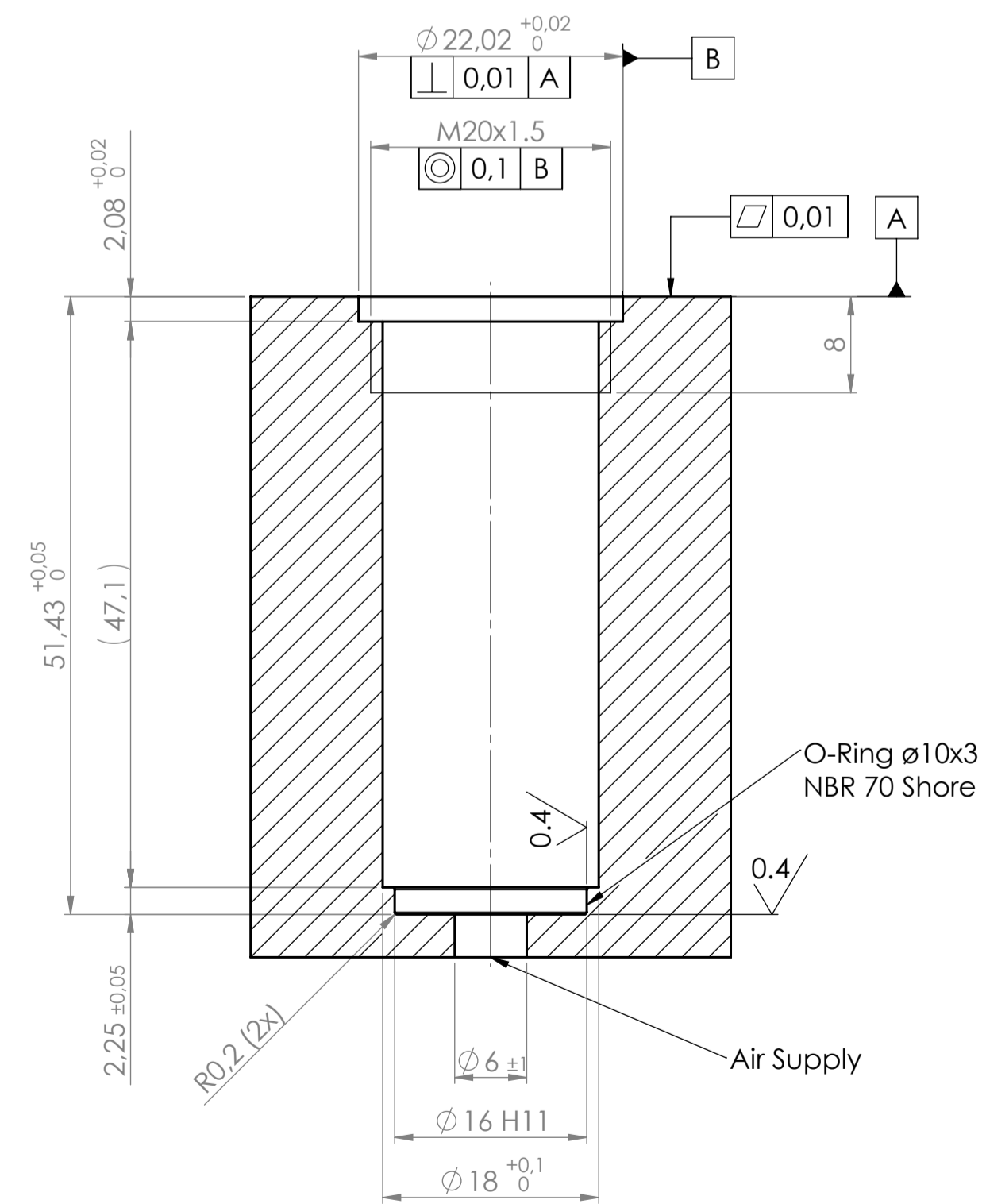

Option 4

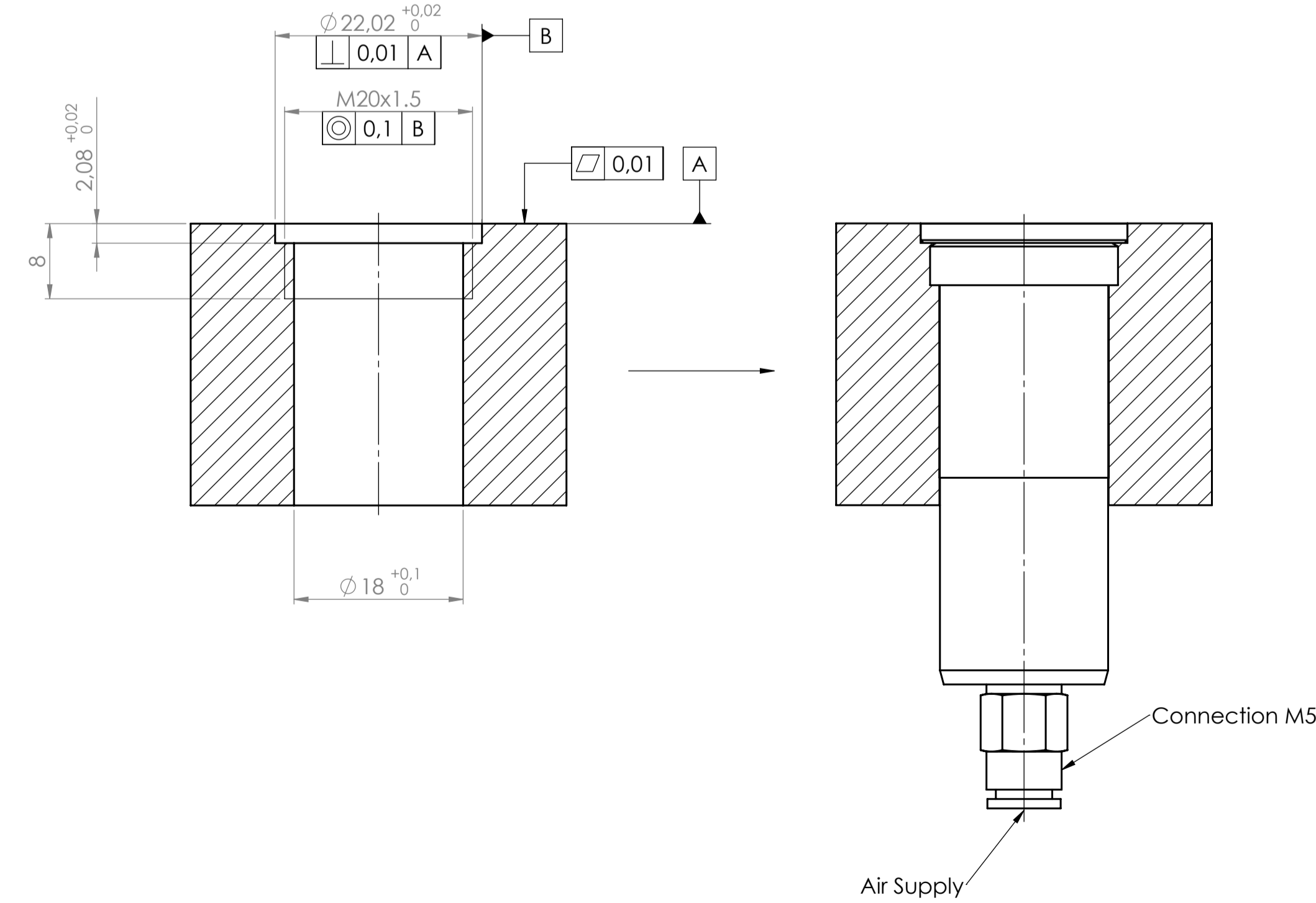

MATERIAL		TREATMENT		DRAWN BY		DRAWN DATE		SCALE		SIZE		SHEET	
InClatec Innovative Clamping Technology		BREAK SHARP CORNERS AND REMOVE BURRS						2:1		A1		1 / 1	
COPYRIGHT © RESERVED		GENERAL ROUGHNESS Ra		DESCRIPTION									
+31 (0)493-399193		GENERAL TOLERANCES		ASSEMBLY HOLES									
www.InClatec.com		DRAWING NR		QuickChange Module QC022 / QC022 C									
		FILENAME											